



**ASM 182 T standard, English
language, 110/130 V and US
power cable**



Similar Image

ASM 182 T standard, English language, 110/130 V and US power cable

- Powerful rotary vane pump with 20 m³/h backing capacity
- 4.4 l/s helium pumping speed
- 110/130 V operating voltage
- US power cable
- Operator interface and voice synthesizer in English

Dimensions

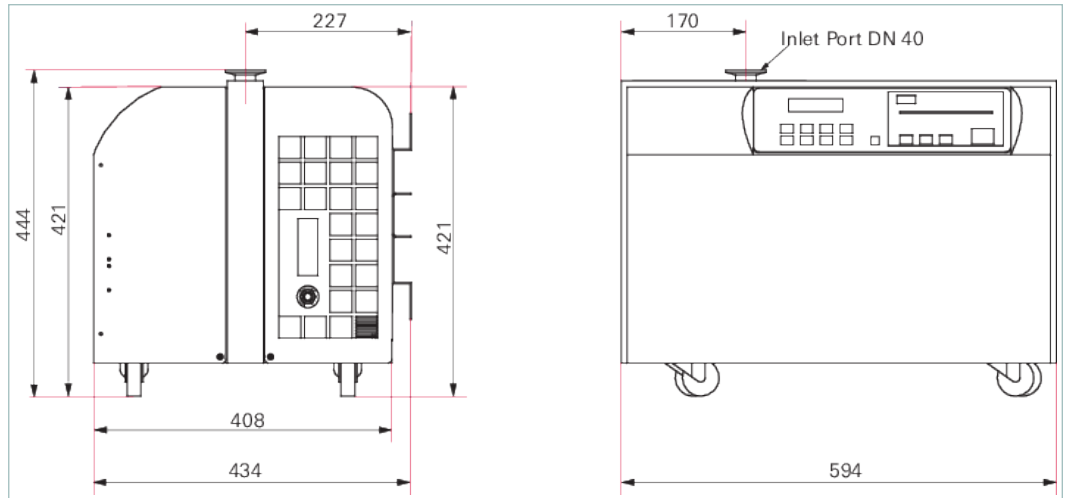

Technical Data	ASM 182 T standard, English language, 110/130 V and US power cable
Backing pump	with oil sealed backing pump
Backing pump capacity	20 m ³ /h
Detectable gases	⁴ He
Dimensions (L x W x H)	594 x 434 x 444 mm 23.39 x 17.09 x 17.48 inch
Flange (in)	DN 40 ISO-KF
I/O interfaces	Digital inputs (Start, Vent, Calibration...); Digital outputs (Test modes, cycle in progress, helium signal above reject set point...); Analog outputs (Helium signal log, Inlet pressure)
Interfaces	RS-232
Language	English
Mains cable	US power cable
Max. inlet test pressure	6 hPa
Minimum detectable leak rate for helium (sniffing leak detection)	1 · 10 ⁻⁸ Pa m ³ /s
Minimum detectable leak rate for helium (vacuum leak detection)	5 · 10 ⁻¹³ Pa m ³ /s
Noise level	54 dB(A)
Operating temperature	10 - 40 °C
Power consumption	1000 W
Pumping speed for He	4.4 l/s
Start-up time (20°C) with calibration	4.5 min
Start-up time (20°C) without calibration	3 min
Supply	110-130 V, 50/60 Hz
Test method	Vacuum and sniffing leak detection

Technical Data	ASM 182 T standard, English language, 110/130 V and US power cable
Type	High Performance - Compact
User interface	Basic user interface
Weight	76 kg 167.55 lb

Order number	
ASM 182 T standard	D20RS00PB710

Accessories	
Inlet filters	
Inlet filter, 20 µm, DN 40/40 ISO-KF	105842
Standard remote control	
Remote control, leak rate in mbar l/s, legend in English	106688
Remote control, leak rate in Pa m ³ /s, legend in English	108880
Remote control, leak rate in Torr l/s, legend in English	108881
Helium spray gun	
Helium spray gun "Elite-Kit", spray gun with additional accessories in a compact case	109951
Helium spray gun, standard	112535
Transport cart	
Transport cart, stainless steel, for ASM 182 T and ASM 182 TD+	111196
Test chambers to be mounted on the inlet flange of ASM 182 series	
Medium aluminium test chamber, cylindrical, internal dimensions: 85 mm diameter, 68 mm height	802456
Large aluminium test chamber, cylindrical, internal dimensions: 160 mm diameter, 100 mm height	802458
Bottle holder	
Bottle holder dedicated for transport cart 111196	802819
Sniffer probe	
Sniffer probe, 5 m hose length, rigid 9 cm nozzle	SNC1E1T1
Sniffer probe, 5 m hose length, flexible 15 cm nozzle	SNC1E3T1

VACUUM SOLUTIONS FROM A SINGLE SOURCE

Pfeiffer Vacuum stands for innovative and custom vacuum solutions worldwide, technological perfection, competent advice and reliable service.

COMPLETE RANGE OF PRODUCTS

From a single component to complex systems:

We are the only supplier of vacuum technology that provides a complete product portfolio.

COMPETENCE IN THEORY AND PRACTICE

Benefit from our know-how and our portfolio of training opportunities!

We support you with your plant layout and provide first-class on-site service worldwide.

Are you looking for a
perfect vacuum solution?
Please contact us:

Pfeiffer Vacuum GmbH
Headquarters · Germany
T +49 6441 802-0
info@pfeiffer-vacuum.de

www.pfeiffer-vacuum.com

All data subject to change without prior notice.

PFEIFFER  **VACUUM**