



MiniTest 300, 100-240 V, 50/60 Hz



Similar Image

MiniTest 300, 100-240 V, 50/60 Hz

- Compact design and low weight, approx. 5 kg
- Detection limit of $5 \cdot 10^{-8}$ Pa m³/s (S = 1 l/s)
- Good water vapor tolerance
- Inlet pressure up to 200 hPa abs.
- Remote control, wireless or with cable, with data logging and USB port
- Connection of an external Compact gauge
- Low maintenance costs

Dimensions

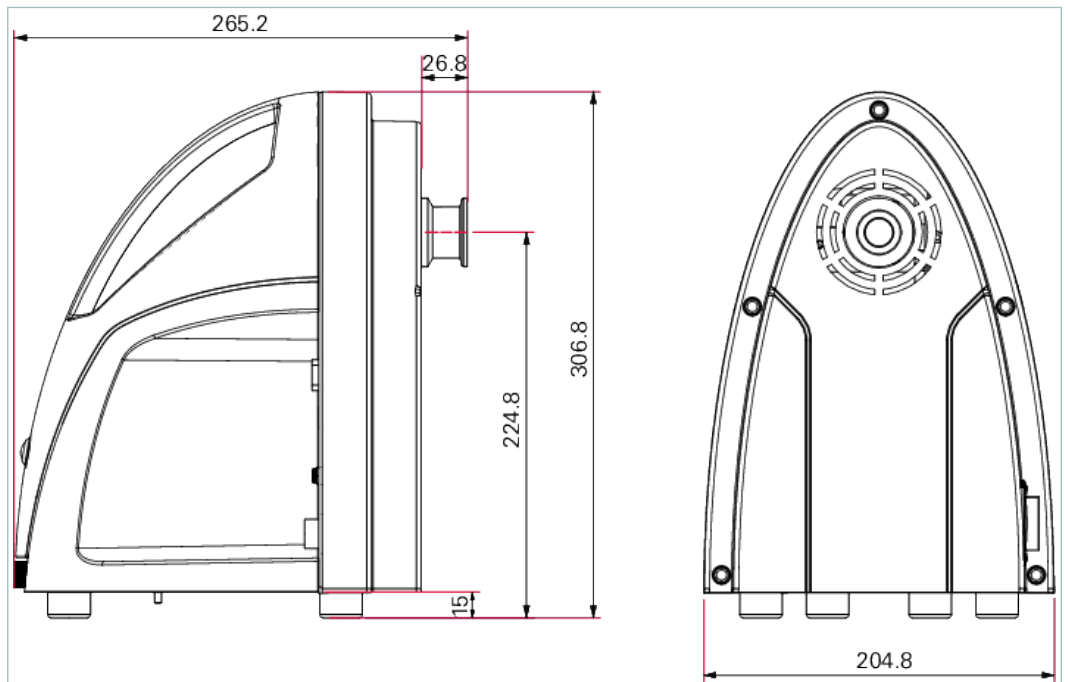

Technical Data	MiniTest 300, 100-240 V, 50/60 Hz
Backing pump	without backing pump
Cold start to ready	30 min
Current consumption	max. 2 A
Flange (in)	DN 25 KF
Inlet pressure max.	200 abs. hPa
Interface	RS-485, RJ-25, Gauge, I/O D-Sub 9, Fernbedienung D-Sub 9
Power consumption	max. 30 VA
Smallest detectable leak rate for ⁴ He (according AVS 2.1)	$1 \cdot 10^{-7}$ Pa m ³ /s
Supply	100–240 V, 50/60 Hz
Temperature: Operating	10 – 35 °C
Temperature: Storage	-10 – 55 °C
Test method	Vacuum leak detection
Type	Mobile
User interface	Operated by remote control RC 500 WL
Weight	5 kg 11.02 lb

Order number

MiniTest 300

PT L03 000

Accessories	
Accessories MiniTest 300	
Centering ring with poral filter, FPM/stainless steel, DN 25 ISO-KF	PF 117 225 -T
Connection cable for remote control unit, 4 m	PT 445 401
Extension cable for remote control unit, 8 m	PT 445 402
Helium pistol	BG 512 125-T
Remote Control RC 500 for helium leak detector	PT 445 421-T
Remote Control RC 500 WL for helium leak detector, wireless	PT 445 420-T
Transportation case for MiniTest	PT 445 428
Tubular test leak with adapter, leak rate ca. $3 \cdot 10^{-3}$ hPa l/s, DN 16 ISO-KF	PT 445 425
Tubular test leak with adapter, leak rate ca. $3 \cdot 10^{-4}$ hPa l/s, DN 16 ISO-KF	PT 445 426
Tubular test leak with adapter, leak rate ca. $3 \cdot 10^{-5}$ hPa l/s, DN 16 ISO-KF	PT 445 427

VACUUM SOLUTIONS FROM A SINGLE SOURCE

Pfeiffer Vacuum stands for innovative and custom vacuum solutions worldwide, technological perfection, competent advice and reliable service.

COMPLETE RANGE OF PRODUCTS

From a single component to complex systems:

We are the only supplier of vacuum technology that provides a complete product portfolio.

COMPETENCE IN THEORY AND PRACTICE

Benefit from our know-how and our portfolio of training opportunities!

We support you with your plant layout and provide first-class on-site service worldwide.

Are you looking for a
perfect vacuum solution?
Please contact us:

Pfeiffer Vacuum GmbH
Headquarters · Germany
T +49 6441 802-0
info@pfeiffer-vacuum.de

www.pfeiffer-vacuum.com

All data subject to change without prior notice.

PFEIFFER  **VACUUM**